

MB8002B-IM

REINFORCEMENT FEEDING DEVICE

Device Model: MB8002B-IM
 Efficiency : 1.5 seconds/ reinforcement
 Reinforcement pad max size :
 20*16 (L * W)(mm)



- YOUR ATTENTION:
1. Once pad size change , mould needs to be replaced accordingly.
 2. This device isTo be applicable to lining material only ,fabric not valid.
 3. Feeding movement set by IMB screen.
 4. Feeding by stepping motor .
 5. Cutter drvien by cylinder.

Machine head is only for representation purpose not part of device.

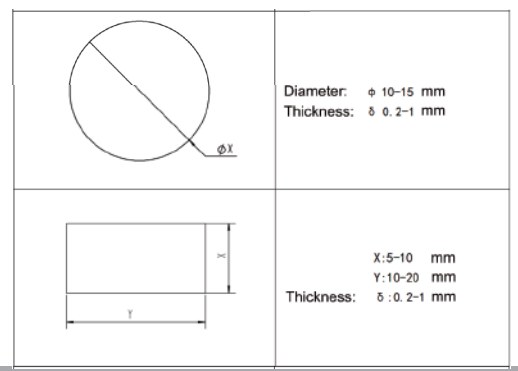

WWW.IMB-CHINA.COM

CHANGZHOU WISDOM & VALLEY ELTECTRIAL TECHONOLY CO.,LTD
 NO.1 QINGYANG ROAD, TIANNING DISTRICT, CHANGZHOU CITY ,JIANGSU,CHINA

